

Snowmass 2001

Accelerator Technology

Benefits to Other Sciences
& to
Society

Alan Jackson, LBNL

Accelerator Components

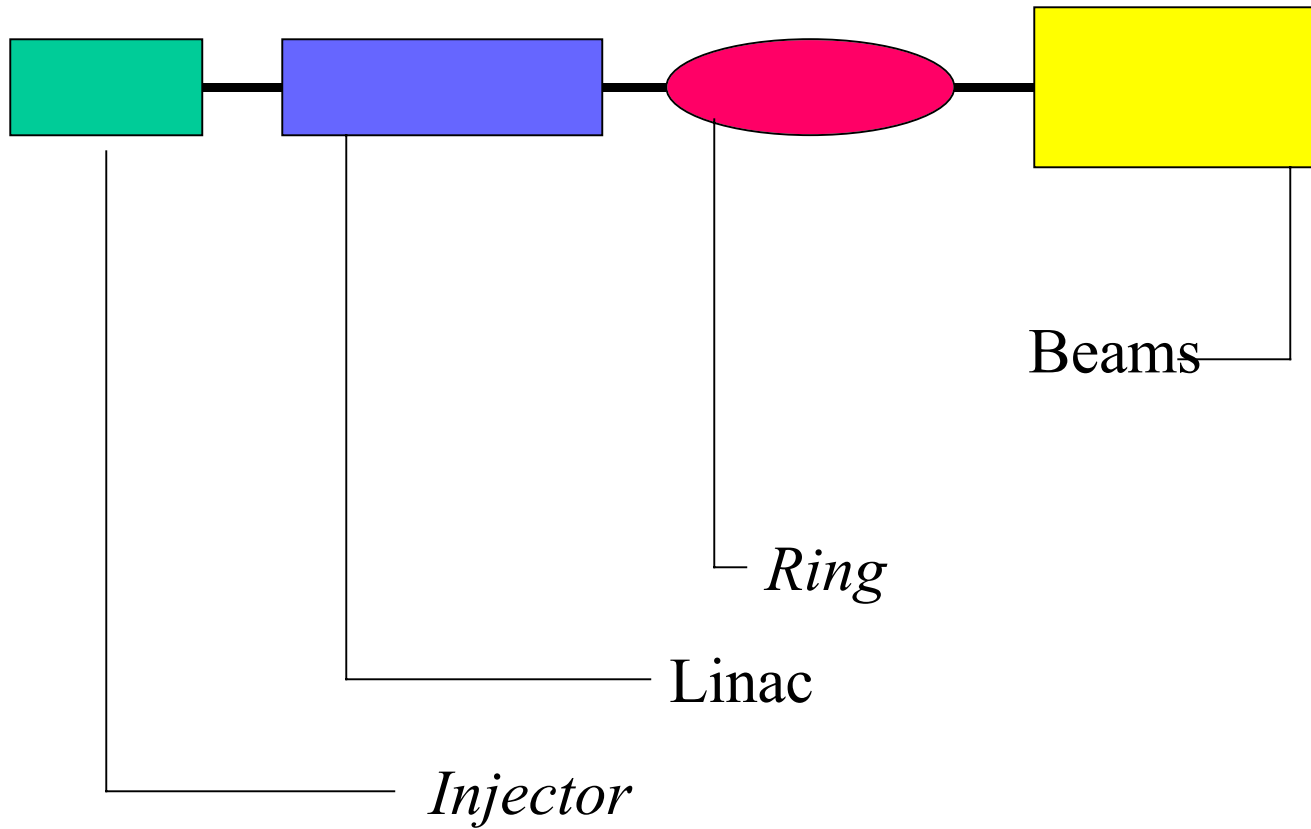

Injectors

- Proton/H⁻
- All ion species ...
- Including radioactive beams
- Electron/positron

Injectors – other uses

- Protons
 - nanowriters, nanolithography
- Deuterons >>> neutrons
 - boron/neutron capture therapy (BNCT)
 - neutron tubes
- Heavier ions
 - fusion
 - ion implanters (chip industry, surface modification, vias, ...)
- Electrons
 - LEED, PEEM, ...

Linacs – other uses

- Electron linacs
 - x-rays for radiation therapy
 - radiography
 - food sterilization
 - FELs
- Proton linacs
 - spallation neutron sources
 - transmutation of nuclear waste
 - radiation therapy
- Heavy ion linacs
 - radiation therapy
 - fusion

Rings – other uses

- Electron rings
 - synchrotron radiation
- Proton rings
 - radiation therapy (Japan, Loma Linda, MGH)
 - production of radio-pharmaceuticals
 - pulse compressors for spallation neutron source
- Superconducting magnets
 - new materials
 - MRI

Beams – other uses

- EM radiation – IR through VUV to x-rays
 - vibration of biological molecules
 - surface physics/catalysis
 - AMO physics
 - chemical sciences – e.g. combustion
 - environmental remediation
 - lithography – optical elements, wafer characterization
 - protein crystallography
 - LIGA
- Neutron beams
 - much as above, but probes at the nuclear level
 - sensitive to magnetic moment (memory industry)

Summary

- Many sciences have benefited *directly* from technologies developed in HEP accelerator R&D
 - biology, chemistry, surface science, AMO, condensed matter, protein crystallography
 - ...
- Likewise, society has reaped many benefits *directly* from technologies developed in accelerator R&D
 - MRI diagnosis, use of radio-pharmaceuticals (including e.g. PET), cancer therapies, next-generation computers, modified engineering materials, improving industrial processes
 - ...

For more info ... Denton TX, “Applications of Accelerators” series